



**More than products. A partnership.**

# NEVA

Rear tractor mower for demanding mowing conditions

The NEVA is a rear boom mower with an arm reach of 5 or 6 meters. It is intended for mowing areas along roads or the canal network.



# Reliable mowing along roads and ditch network

The NEVA rear mower is a tractor-mounted mower available in arm configurations of 5 or 6 meters. NEVA is intended for more demanding tasks of mowing grass, weeds, shrubs and similar vegetation along roads and canal networks. NEVA can be equipped with various models of professional mowing heads or working tools intended for cleaning channels or cutting branches.

The design of the NEVA mower allows easy manoeuvring between obstacles and fast arm movements, which makes it a reliable choice for more demanding terrains and provides complete comfort to the user.

The mower is equipped with advanced intuitive arm control systems, located in the vehicle cabin. The control system, depending on user's preferences, can be selectively proportional (SelectMotion) or fully proportional (TotalMotion).

The arm relief system allows vertical tracking of the terrain, while the floating system adjusts the position of the working head to the surface. The oil cooler located next to the hydraulic power unit prevents overheating of the hydraulic oil and ensures uninterrupted operation during long-term mowing at high temperatures.

In the transport position, the mower is located at the rear of the vehicle and marked with light signals in accordance with legal regulations, which allows safe participation in traffic. Easy and safe mounting and demounting quickly discharges the tractor for other purposes.



## WHY CHOOSE NEVA BOOM MOWER?



### ✓ Mowing efficiency

The advanced intuitive control system ensures easy operation of the arms and working tools, while the external oil cooler located next to the hydraulic power unit prevents the oil from overheating and ensures long-lasting and uninterrupted mowing.



### ✓ Ease of use

The design of the mower allows the operator to easily manoeuvre between obstacles and fast arm movements, easier mowing on more demanding terrains, and provides comfort to the operator.



### ✓ Work faster

The NEVA rear boom mower can be quickly mounted and dismounted on/off the tractor rear three-point hitch, which equips the tractor for the mowing season, or free it for other purposes. Working tools can also be changed quick and easy, turning the mower into a tool for cutting branches or ditch cleaning.



### ✓ Lowest total cost of ownership

Unique surface protection system, ease of use and maintenance, robust design and high-quality materials guarantee a safe investment in the NEVA mower.

Proven durability, safety, efficiency, and simplicity, as well as the availability of spare parts and after-sales support, guarantee the lowest total cost of ownership currently available on the market.



**1 | Operation**

The mower is equipped with an advanced and intuitive arm control system and working tools located in the vehicle cabin. The control system, depending on the users' preferences, can be selective proportional (SelectMotion) or fully proportional (TotalMotion). The control system provides complete control over the machine and enables safe and simple mowing.

**2 | Hydraulic power unit**

Used for powering of the working tool hydraulic engine and the hydraulic cylinders for operating the arms. It is driven via the cardan output of the tractor on which the mower is installed.

**3 | Arms**

Reliable and durable, they are made from high-quality steel, with a reach of 5 or 6 meters. They provide excellent work results and serve as a universal carrier for various work tools.

**4 | Hydraulic oil cooler**

Located next to the oil tank, it prevents the hydraulic oil from overheating and ensures long-lasting and uninterrupted operation, regardless of the outside temperatures.

**5 | Mower mounting frame**

Used for mounting the mower on the rear three-point hitch of the tractor.

**6 | Additional fixing elements**

For additional stability in operation, two "top link" levers are installed on the three-point hitch. If working with the mower requires additional three-point hitch capacity, a special support frame that connects to the rear axle of the tractor can be installed.

**7 | Boom mower relief system**

Ensures adapting to the uneven terrains, while the 'floating' system adjusts the position of the working head to the surface. This reduces the load on the hydraulic and mechanical construction of the mower and extends the service life of the device.

**8 | Swiveling mechanism**

It consists of a hydraulic cylinder that allows the mower to quickly turn from transport to the working position. It is also a safety element when the working tool gets stuck on an obstacle.

**9 | Rear signalization**

Enables a good visibility of the mower and the vehicle to which it is mounted and provides a high degree of safety for the user and all other traffic participants.

**10 | Storage outside the season**

Made easier using a supporting cart that enables simple mounting and demounting of the mower. The storage cart protects the mower and the surface on which it is stored from damage.

**11 | Working tools and attachments**

They are easy to replace, and the wide selection between tools give each RASCO boom mower the possibility of working on different terrains and maintenance of different types of vegetation.

# Intuitive control systems developed for the user

The control of the boom mower is enabled through an advanced control unit located inside the vehicle cabin. It consists of a joystick for arms and working tools operation, and a colour display with working commands for mower relief, floating position, and additional functions.

Depending on the terrain, which is being maintained, and user preferences, there are two control systems available:



## SELECTMOTION

### Selective proportional control

Selective proportional control allows easy operation of the mower's arm and working tool on more demanding terrains. Each movement of the joystick results in the movement of one selected hydraulic cylinder. Therefore, moving the arms to the desired position requires more movement of the joystick.

## TOTALMOTION

### Fully proportional control

Fully proportional control is intended for working on difficult terrains, full of obstacles, where continuous manoeuvring with arms is required. Control with the use of joystick allows quick changes of the arm position, through the movement of several cylinders in one joystick movement.

# Continuous work in all conditions

The boom mower is driven by a separate hydraulic unit driven by the power of the vehicle on which the mower is installed. Three types of hydraulic pumps can be installed in the hydraulic unit, depending on the mode of operation of the mower and the type of terrain being maintained:

### Hydraulic system with tandem gear pump

Ideal for low to medium intensity work, e.g., mowing grass and vegetation along roads;

### Hydraulic system with tandem piston and gear pump

Ideal for medium to demanding working conditions such as mowing and maintaining vegetation along canal networks

### Cooling of the boom mower

The specially designed oil cooler prevents the hydraulic oil from overheating and ensures long-term and uninterrupted operation of the mower, regardless of outside temperatures.



## HYDRA

HYDRA is a combined working head for mowing and cutting vegetation up to 50 mm thick. Efficient operation of the HYDRA mowing head is enabled by the design of its key parts. The spiral distribution of the blades reduces energy consumption, and the increased opening at the back of the head allows a high flow of material, and accordingly, a higher mowing speed.

The HYDRA mowing head can be equipped with different types of blades, which enables it to adapt on any type of terrain which is being mowed.



## TORNADO

TORNADO mowing heads are an ideal choice for maintaining smaller vegetation. They are designed to provide the possibility of using two types of blades for cutting vegetation of different thickness, with a diameter of 15 to 30 mm.

The rotor design and the blade selection make TORNADO the ideal choice for the maintenance of urban areas.



## SRG

SRG are branch cutters, specially designed for removing the tops of trees, as well as large and small vegetation up to 100 mm thick.



## BM

BM is a brush designed for removing grass, dirt and leftover winter season spreading agent from roads.



## KAN

KAN is a ditch cleaner, designed for cleaning and profiling ditches along roads.

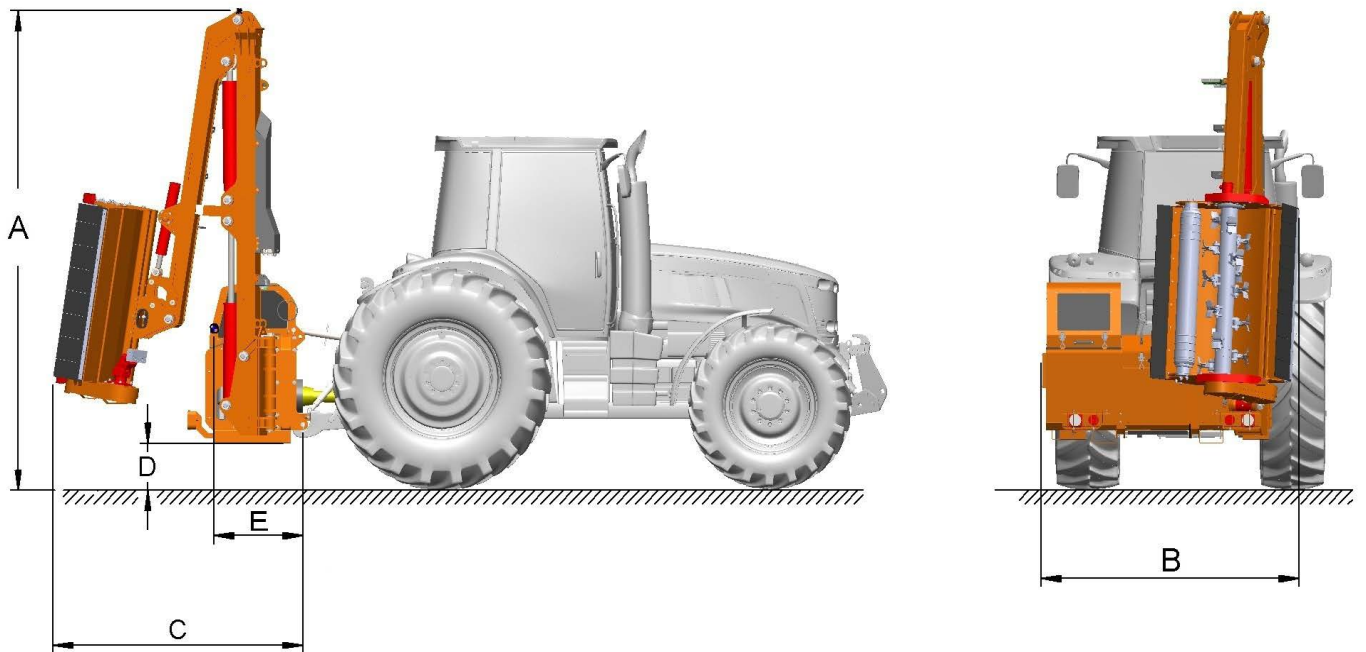

NEVA		5000	6000
<b>A</b>	Total boom mower height	3150	3560
<b>B</b>	Total boom mower width	1980	1980
<b>C</b>	Length of the boom mower in the transport position	1800	1890
<b>D</b>	Distance of power unit from the ground	350	350
<b>E</b>	Distance of centre of mass from connecting point of hydraulic levers	660	670



**RASCO d.o.o.**  
 Kolodvorska 120b  
 HR - 48361 Kalinovac  
 CROATIA

+385 48 883 112  
 rasco@rasco.hr

RascoCompany  
 Rasco\_company

RascoTV  
 RASCO d.o.o.