



More than products. A partnership.

SPECTRA

Rear tractor boom mower

SPECTRA is a rear boom mower with an arm reach of 6 or 7 meters.

It is specially designed for reliable and fast mowing, thanks to arm kinematics which enable the users to have the working tool in their field of view.



High mowing visibility and simple mounting

Boom mower SPECTRA is a rear tractor mower designed for reliable and fast mowing, available in configurations with an arm reach of 6 or 7 meters. SPECTRA is designed for mowing grass, weed, bushes, and similar vegetation to maintain surfaces by the side of roads, forest paths overgrown with rank vegetation, and ditch networks.

SPECTRA is fully designed with the users' needs in mind. One of its main features are specially designed mower arm kinematics which enable the working tool to be aligned with the operator, thus increasing visibility and safety during operation.

The mower is equipped with advanced intuitive arm operation systems, which are located in the vehicle cabin. Depending on the users' preferences, the control system can be selective proportional (SelectMotion) or full-proportional (TotalMotion).

Arm relief system enables vertical monitoring of the terrain, while the floating system adjusts the position of the operating head to the surface level. The oil cooler next to the aggregate prevents overheating of the hydraulic oil, ensuring uninterrupted and precise operation when mowing at high temperatures for an extended period of time.

SPECTRA can be equipped with various models of professional mowing heads or working tools designed for ditch maintenance or cutting branches.

In the transport position, the mower is located at the rear side of the vehicle and marked with signalling devices in accordance with laws and regulations, enabling safe participation in traffic. Simple and safe mounting and demounting quickly frees the tractor for other purposes.



✓ **Mowing efficiency**

Advanced intuitive control system enables simple operation of the arms and the working tool, while the external oil cooler next to the aggregate prevents overheating of the oil, ensuring long-lasting and uninterrupted mowing.



✓ **Working tool visibility**

Specially designed arm kinematics bring the working tool in the user's visual field, increasing the mowing visibility and the safety of operation.



✓ **Simple operation**

SPECTRA rear boom mower is simple to mount and demount from the rear three-point attachment, quickly equipping the tractor for the mowing season as well as quickly freeing it for other purposes.



✓ **Lowest cost of ownership**

Its unique surface protection system, ease of use and maintenance, robust design, and high quality materials guarantee a safe investment in the SPECTRA mower.

Proven durability, safety, efficiency, simplicity, and availability of spare parts and post-sales support guarantee the lowest overall cost of ownership currently available on the market.



1 | Operation

The mower is equipped with an advanced intuitive control system for arm and working tool operation located in the vehicle cabin. Depending on the users' preferences, the control system can be selective proportional (SelectMotion) or full-proportional (TotalMotion). It provides full control over the device and enables safe and simple moving.

2 | Hydraulic aggregate

Powers the working tool hydraulic engine and the hydraulic cylinders for arm operation. It is powered by the output drive shaft of the tractor on which the mower is mounted.

3 | Crane arms

Reliable and durable, they are made out of high quality steel and have a reach of 6 or 7 meters. They provide excellent results and serve as universal support for various working tools.

4 | Oil cooler

Situated next to the oil tank, it prevents overheating of the hydraulic oil and ensures long-lasting and uninterrupted operation, regardless of outdoor temperatures.

5 | Supporting frame

Used for mounting the mower on the rear tractor three-point attachment.

6 | Additional reinforcement of the rear three-point attachment

For extra stability during operation, two top-link levers are mounted on the three-point attachment. If the load capacity of the three-point attachment needs to be increased, a special supporting frame can be connected to the rear axle of the tractor.

7 | Relief system

Enables good control over uneven terrain, while the floating system adjusts the position of the operating head to the surface level. This reduces the load on the mower's hydraulic and mechanical construction, thus extending the lifespan of the device.

8 | Rotating mechanism

Consists of a hydraulic cylinder which enables rotation of the mower into the working position. It also has the function of a safety element in case the working tool encounters an obstacle.

9 | Rear signalization

Enables a good visibility of the mower and vehicle to which it is mounted, and offers a high degree of safety for the user and all other traffic participants.

10 | Storage outside the season

This is made easier through the use of a supporting cart that enables simple mounting and demounting of the mower. When it is not in use, the cart protects the mower and the surface on which it is placed from damage.

11 | Working tools and attachments

They are easy to replace, and their wide selection offers the possibility of use on various terrains and for maintenance of different types of vegetation for each RASCO boom mower.

BOOM MOWER CONTROL

Intuitive control systems adjusted to the user

Boom mower control is enabled through an advanced control unit located inside the vehicle cabin. It consists of a joystick for crane arm and working tool operation as well as a multi-colour display with relief, floating position, and other commands.

Depending on the structure of the terrain to be maintained and user preferences, two control systems are available:



SELECTMOTION

Selective proportional control

Selective proportional control enables simple control of the mower arm and the attached working tool on more demanding terrains.

Each movement of the joystick results in the movement of the selected hydraulic cylinder. Therefore, moving the arms into the desired position requires the joystick to be moved several times.

TOTALMOTION

Full proportional control

Full proportional control is intended for controlling mowers on difficult terrains, full of obstacles, requiring continuous manoeuvring of arms.

Control with the use of a joystick enables quick changes of the arm position through the movement of several cylinders with one movement.

BOOM MOWER DRIVE

Uninterrupted operation in all conditions

The boom mower is driven by a separate hydraulic unit driven by the power of the vehicle on which it is mounted mower built-in. Three types of hydraulic pumps can be installed in the hydraulic unit depending on the method of working with the mower and the type of terrain that is maintained:

Hydraulic system with tandem gear pump

Ideal for low to medium intensity work, eg mowing grass and vegetation along roads;

Hydraulic system with tandem piston and gear pump

Ideal for medium to demanding working conditions such as mowing and maintaining vegetation along canals network;

LS hydraulic system

Advanced hydraulic system ideal for difficult mowing conditions when the mower is running non-stop. The LS hydraulic system is intended for all-day demanding mowing work and enables fuel savings.

Boom mower cooling

A specially designed oil cooler prevents overheating of the hydraulic oil and ensures long-lasting and uninterrupted operation of the mower, regardless of outdoor temperatures.

MOWING HEADS AND WORKING TOOLS



HYDRA

HYDRA is a combined operating head for mowing and fragmenting vegetation up to 50 mm thick. Efficient operation of the HYDRA mowing head is enabled by the design of its key parts. The spiral distribution of blades reduces energy loss, and an increased aperture on the rear end of the head enables high outflow of material, and accordingly, a higher mowing speed.

The HYDRA operating head can be equipped with different types of blades, which enables it to be adjusted in accordance with the requirements for mowing all types of vegetation.



TORNADO

TORNADO mowing heads are the ideal choice for the maintenance of smaller vegetation. They are designed to provide the possibility of using two types of blades for cutting vegetation of different thickness, with a diameter of 15 to 30 mm.

The rotor design and the knife selection make TORNADO the ideal choice for the maintenance of urban areas.



SRG

SRG are branch cutters, specially designed for removing the tops of trees as well as large and small vegetation up to 100 mm thick.



BM

BM is a brush designed for removing grass, dirt, and leftover winter season spreading agent from roads.



KAN

KAN is a ditch cleaner, designed for cleaning and profiling ditches by the side of roads.

TECHNICAL CHARACTERISTICS

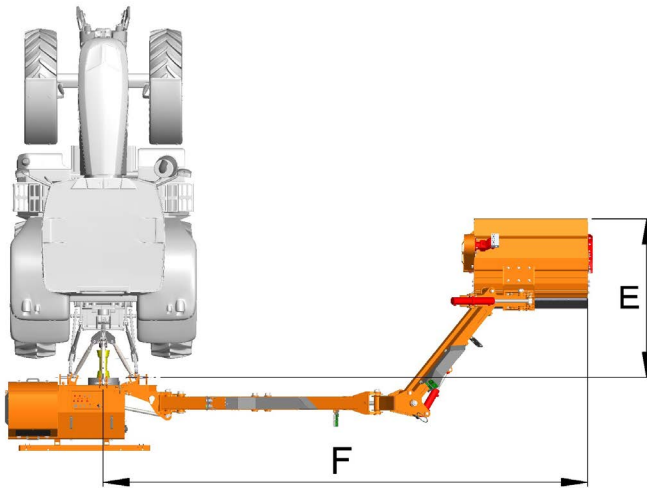
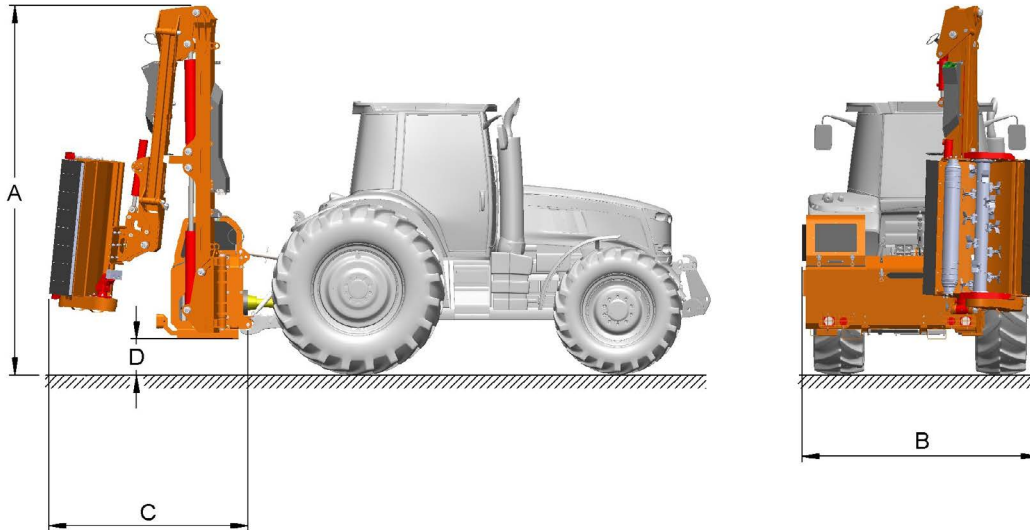

SPECTRA		6000	7000
A	Total boom mower height	3560	3990
B	Total boom mower width	2280	
C	Length of the boom mower in the transport position	1900	
D	Distance of power unit from the ground	350	400
E	Working head forward movement	1880	2230
F	Maximum range with the working head moved forward	5540	6250



 **RASCO d.o.o.**
Kolodvorska 120b
HR - 48361 Kalinovac
CROATIA

 +385 48 883 112
 rasco@rasco.hr

 RascoCompany
 Rasco_company

 RascoTV
 RASCO d.o.o.