



More than products. A partnership.

VERTUS

Snow plough with variable wing geometry

VERTUS is a variable snow plough available in sizes ranging from 3.0 to 3.6 meters, designed for mounting on all types of vehicles. VERTUS is intended for a wide range of applications in snow clearing due to variable wing geometry which enables several different plough configurations.



Three snow clearing options in one snow plough

VERTUS ploughs are intended for a wide range of applications due to variable wing geometry which enables several different plough configurations. In the diagonal position, the plough removes snow to the left or right side; the position "A" is used for first passage through deep snow and clearing narrow passes, while the "V" position is intended for snow collection without lateral removal.

Variable geometry of VERTUS ploughs makes them suitable for performing several different winter service tasks, from a plough for making passages to a plough for collecting snow. The plough is primarily intended for cities with narrow streets, mostly covered with parked vehicles, where its variable geometry and adaptability to the width of the area being cleared is put to best use.

Intended for clearing snow in urban areas, the VERTUS ploughs have numerous mechanisms that guarantee safe and efficient clearing of snow. The swiveling scraper mechanism ensures simple transition over obstacles without damage to the road surface, supporting elements prevent the plough from digging into the ground and protect the scrapers from damage, while reflective marks make the plough visible even in the most difficult weather conditions. Bumpers on each wing protect the plough from damage when encountering obstacles such as walls or high curbs.

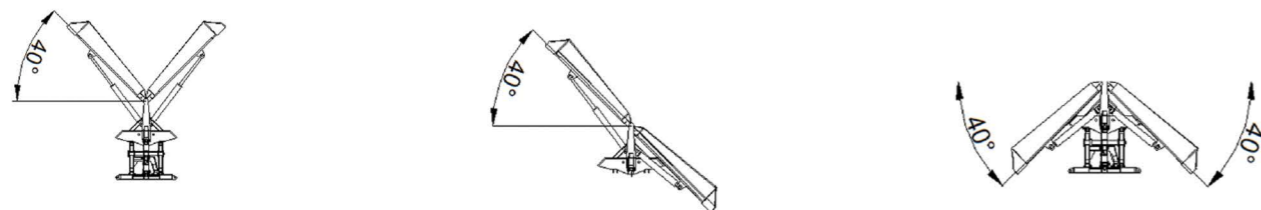

✓ **Solution for city and local road clearing conditions**

VERTUS is an excellent choice for clearing snow from city and local roads, mostly covered with parked vehicles, where its variable geometry and adaptability to the width of the area being cleared is put to best use.



✓ **Variable wing geometry for maximum clearing efficiency**

In the diagonal position, the plough removes snow to the left or right side; the position "A" is used for first passage through deep snow and clearing narrow passes, while the "V" position is intended for snow collection without lateral removal.



✓ **Safe urban area clearing**

VERTUS ploughs have numerous mechanisms that guarantee safe and efficient clearing of snow. The swiveling scraper mechanism ensures simple transition over obstacles without damage to the road surface, supporting elements prevent the plough from digging into the ground and protect the scrapers from damage, while reflective marks make the plough visible even in the most difficult weather conditions. Bumpers on each wing protect the plough from damage when encountering obstacles such as walls or high curbs.



✓ **Lowest cost of ownership**

Its unique surface protection system, easiness of use and maintenance, robust design, high quality materials guarantee a safe investment in the VERTUS plough. Proven durability, safety, efficiency, simplicity, and availability of service parts and post-sales support guarantee the lowest total cost of ownership of a snow plough currently available on the market.

CHARACTERISTICS OF MACHINE PARTS



1 | Plough wings

The plough wings are made using robotic welding technology. The precise, computer-controlled production process ensures uniform quality of all plough elements. The SurfaceArmour surface protection system in combination with the welding technology and the chosen material for production serve as a guarantee of product durability and longevity.

7 | Supporting elements

Slide pads and auxiliary wheels support the plough's weight and prevent the plough from digging into the ground. They extend the lifespan of scrapers and protect the plough and the surface that is being cleared from damage.

2 | Attack angle of the plough wing

VERTUS has an attack angle of 0°, with a rotation angle range of 0° to 40°.

8 | Side bumpers

They are placed on the outer plough wings and prevent the damage of wings from side impacts of obstacles on the surface that is being cleared. Just like scrapers, they are disposable plough elements and can be easily replaced.

3 | Scrapers

VERTUS ploughs can be equipped with steel or rubber scrapers. VERTUS can be equipped with four mutually independent tilting scrapers mechanisms – two of them per wing.

4 | Mounting system

It enables the attachment of snow ploughs on vehicles in several ways – using different types of mounting plates for trucks and working vehicles or by front three-point attachment on tractors.

5 | Protection from snow

This protection is installed on the plough wing and protects the windshield from snow spray, thus enabling safe and unhindered ploughing.

6 | Traffic signalisation

It improves the visibility of the snow plough and vehicle, thus ensuring safety during operation and transport. This may include flags, reflective marks, raised front headlights and turn indicators.

Easy mounting on all types of vehicles

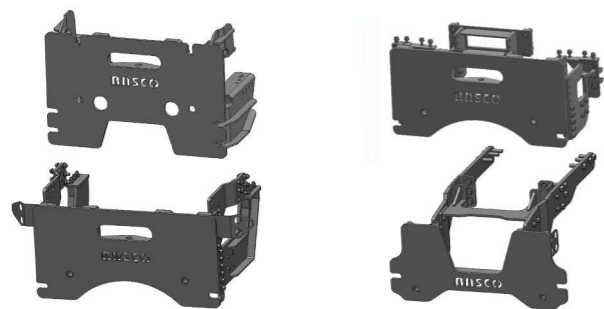

Mounting using mounting plates

RASCO offers the possibility of manufacturing and installing mounting plates for various models of trucks and tractors. All mounting plates are created in accordance with the current standards, which guarantees high quality and resistance to damage such as torsion or bending.

Designed for complete efficiency during the operation of attachments and adjustable according to vehicle height, mounting plates enable fast and simple installation of snow ploughs on nearly all types of vehicles.

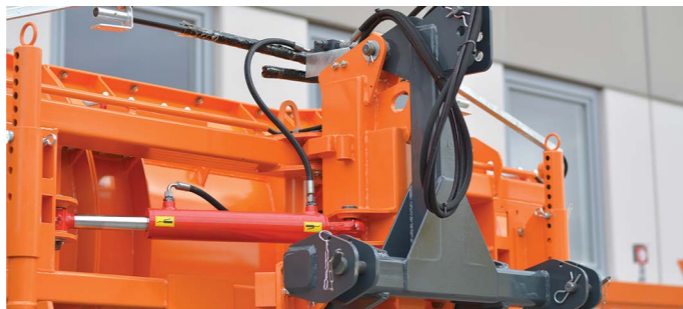

Front three-point attachment on tractors.

With the possibility of installing a front panel on a tractor, RASCO snow ploughs can be easily mounted on the front three-point attachment of the tractor if the tractor is adequately equipped.



Solution for vehicles with and without built-in hydraulic system

Vehicles with built-in hydraulic system

VERTUS ploughs can be powered using a built-in hydraulic system of the vehicle if it is designed according to the EN ISO 15431 standard.

Vehicles without built-in hydraulic system

Power via electro-hydraulic power unit

One of the methods of powering the snow plough is the installation of an electro-hydraulic power unit (EHAG) that connects to the vehicle's electrical system. The EHAG is recommended when there is no need for frequent adjustments of the position of the plough, as is the case with open intercity roads, otherwise the battery of the vehicle may be discharged.

Power via diesel-hydraulic power unit

The snow plough can also be powered by connecting it to a diesel-hydraulic power unit installed on the spreader. Powering via the diesel-hydraulic power unit is recommended when the vehicle is not equipped with an adequate hydraulic system.

Solutions for different types of hydraulic systems

BASIC – vehicle hydraulic installation control system only, designed for vehicles with 4 pairs of hydraulic couplings. With this solution, VERTUS is fully operated via hydraulic couplings – one for raising/lowering the plough, one for tilting the whole plough wing to the left/right, one for rotating only the left wing, and one for rotating only the right wing.

SYNCR0 – hydraulic installation control system, designed for vehicles with 3 pairs of hydraulic couplings. In this control system, the vehicle is equipped with an additional switch for switching between left wing and right wing tilt mode.

RASCOMATIC – hydraulic installation control system, designed for vehicles with 2 pairs of hydraulic couplings. In this control system, the vehicle must be equipped with an additional switch for switching between various modes depending on the position of the switch – turning the plough to the left/right, tilting only the left wing forwards or backwards, and tilting only the right wing forwards or backwards.

TECHNICAL CHARACTERISTICS

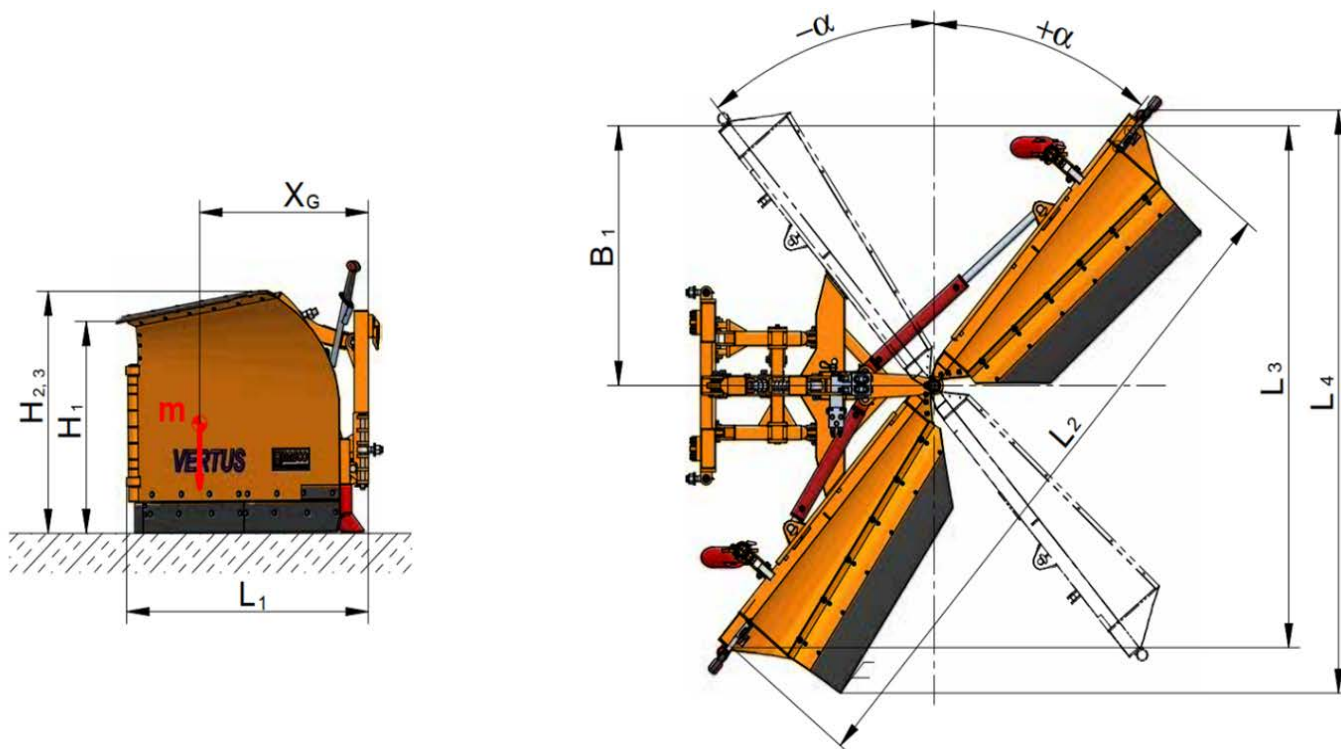

Model	H1	H2, 3	L1	L2	L3		L4		α	β
	Height of the inner wing	Height of the outer wing	Distance between the tip of a scraper and the mounting plate	Width on scrapers	Clearing width at 36° rotation angle	Clearing width at 40° rotation angle	Total width at 36° rotation angle	Total width at 40° rotation angle	Rotation angle	Attack angle
mm										
3.0	960	1100	1295	3000	2450	2300	2500	2600	0 - 36° / 0 - 40°	0°
3.2				3200	2600	2450	2650	2760		
3.4	1100	1250		3400	2750	2600	2800	2900		
3.6				3600	2920	2750	2950	3050		

CHOICE OF EQUIPMENT

- Steel scrapers
- Rubber scrapers
- Front-panel attachment with level cylinder
- Front tractor hydraulic lever three-point attachment
- Slide pads
- Auxiliary wheels
- Protection from snow
- Reflective marks
- Turn indicators
- Clearance marker lights
- Flags



RASCO d.o.o.
Kolodvorska 120b
HR - 48361 Kalinovac
CROATIA

+385 48 883 112
rasco@rasco.hr

RascoCompany
Rasco_company

RascoTV
RASCO d.o.o.