



More than products. A Partnership.

BRK

Side mounted boom mower

BRK is a strong side mounted boom mower with arm reach of 5, 6 or 7 metres.

It is specially designed for demanding mowing on wide roadsides, water ditches and water channels.



Strong side mounted mower for demanding mowing

BRK is a side boom mower designed for more demanding mowing work, available in arm configurations up to 5, 6 or 7 meters. It is primarily intended for mowing grass, weeds, shrubs, and similar vegetation on large areas along roads, embankments along waterways and along canals.

The boom mower is mounted laterally, between the tractor axles. Special construction of arms guarantees efficient mowing even at higher speeds, reduced vibrations, and operator comfort.

The mower is equipped with advanced intuitive arm control systems, located in the vehicle cabin. The control system, depending on the user's preferences, can be selectively proportional (SelectMotion) or fully proportional (TotalMotion).

The arm relief system allows vertical tracking of the terrain, while the floating system adjusts the position of the working head to the surface. The oil cooler located next to the hydraulic power unit prevents overheating of the hydraulic oil, therefore ensuring uninterrupted and precise operation during long-term mowing at high temperatures.

BRK can be equipped with different models of professional working heads for mowing or working tools intended for channel maintenance or cutting branches.

In the transport position, the mower is placed at the rear of the vehicle and marked with light signals aligned with legal regulations, which ensures good visibility and safe participation in traffic.



WHY CHOOSE BRK BOOM MOWER?



✓ Mowing efficiency

The BRK is installed laterally, between the front and rear axles of the tractor, which makes it stable and safe. The operator has excellent working visibility, more comfort, and can easily avoid obstacles (traffic signs, etc).



✓ For demanding terrains

Robustness and arm reach of up to 5, 6 or 7 meters guarantee efficient maintenance of canals along open roads or embankments along waterways. The choice between three different versions of the hydraulic power unit allows complete adjustment to the terrain.



✓ Simple and intuitive operation of the boom mower

The BRK boom mower is available with two control systems: SelectMotion, which allows easy control of the mower's arm and working tools on more demanding terrains, and TotalMotion, which is primarily intended for controlling mower on difficult terrains, where continuous arm maneuvering is required.



✓ Total lowest cost of ownership

Its unique surface protection system, ease of use and maintenance, robust design, and high-quality materials guarantee a safe investment in the BRK mower.

Proven durability, safety, efficiency, and simplicity, as well as the availability of spare parts and after-sales support, guarantee the lowest total cost of ownership currently available on the market.



- | | | | | | |
|---|---|---|---|---|---|
| <p>1 Operation</p> <p>The mower is equipped with an advanced and intuitive arm control system and working tools located in the vehicle cabin. The control system, depending on the users' preferences, can be selective proportional (SelectMotion) or fully proportional (TotalMotion). The control system provides complete control over the machine and enables safe and simple mowing.</p> | <p>2 Hydraulic power unit</p> <p>Used for powering of the working tool hydraulic engine and the hydraulic cylinders for arms operating. It is driven via the cardan output of the tractor on which the mower is installed.</p> | <p>3 Arms</p> <p>Reliable and durable, they are made out of high quality steel, with a reach of 5, 6 or 7 meters. They provide excellent work results and serve as a universal carrier for various working tools.</p> | <p>4 Hydraulic oil cooler</p> <p>Located next to the oil tank, it prevents the hydraulic oil from overheating and ensures long-lasting and uninterrupted operation, regardless of the outside temperatures.</p> | <p>5 Mower mounting frame</p> <p>A specially adapted mounting frame is used to install the mower between the tractor axles. The installation of the side mower is most often done in the RASCO factory. Our expert vehicle upgrade team creates a specially tailored frame for each tractor, which guarantees the stability of the overall composition, safety and smooth operation.</p> | <p>6 Boom mower relief system</p> <p>Ensures adapting to the uneven terrains, while the 'floating' system adjusts the position of the working head to the surface. This reduces the load on the hydraulic and mechanical construction of the mower and extends the service life of the device.</p> |
| <p>7 Swiveling mechanism</p> <p>It consists of a hydraulic cylinder that allows the boom mower to quickly turn from transport to the working position. It is also a safety element when the working tool gets stuck on an obstacle.</p> | <p>8 Rear signalization</p> <p>Enables a good visibility of the mower and the vehicle to which it is mounted, and provides a high degree of safety for the user and all other traffic participants.</p> | <p>9 Storage outside the season</p> <p>Made easier through the use of a supporting cart that enables simple mounting and demounting of the mower. The storage cart protects the mower and the surface on which it is stored from damage.</p> | <p>10 Working tools and attachments</p> <p>They are easy to replace, and the wide selection between tools give each RASCO boom mower the possibility of working on different terrains and maintenance of different types of vegetation</p> | | |

Intuitive control systems developed for the user

The control of the boom mower is enabled through an advanced control unit located inside the vehicle cabin. It consists of a joystick for arms and working tools operation, and a color display with working commands for mower relief, floating position, and additional functions.

Depending on the terrain which is being maintained, and user preferences, there are two control systems available:



SELECTMOTION

Selective proportional control

Selective proportional control allows easy operation of the mower's arm and working tool on more demanding terrains. Each movement of the joystick results in the movement of one selected hydraulic cylinder. Therefore, moving the arms to the desired position requires more movement of the joystick.

TOTALMOTION

Fully proportional control

Fully proportional control is intended for working on difficult terrains, full of obstacles, where continuous manoeuvring with arms is required. Control with the use of joystick allows quick changes of the arm position, through the movement of several cylinders in one joystick movement.

Continuous work in all conditions

The boom mower is driven by a separate hydraulic unit driven by the power of the vehicle on which the mower is installed. Three types of hydraulic pumps can be installed in the hydraulic unit, depending on the mode of operation of the mower and the type of terrain being maintained:

Hydraulic system with tandem gear pump

Ideal for low to medium intensity work, eg mowing grass and vegetation along roads.

Hydraulic system with tandem piston and gear pump

Ideal for medium to demanding working conditions such as mowing and maintaining vegetation along canal networks.

LS hydraulic system

Advanced hydraulic system ideal for difficult mowing conditions when the mower is running non-stop. The LS hydraulic system is designed for all-day demanding mowing work and enables fuel savings.

Cooling of the boom mower

The specially designed oil cooler prevents the hydraulic oil from overheating and ensures long-term and uninterrupted operation of the mower, regardless of outside temperatures.



HYDRA

HYDRA is a combined working head for mowing and cutting vegetation up to 50 mm thick. Efficient operation of the HYDRA mowing head is enabled by the design of its key parts. The spiral distribution of the blades reduces energy consumption, and the increased opening at the back of the head allows a high flow of material, and accordingly, a higher mowing speed.

The HYDRA mowing head can be equipped with different types of blades, which enables it to adapt on any type of terrain which is being mowed.



TORNADO

TORNADO mowing heads are an ideal choice for maintaining smaller vegetation. They are designed to provide the possibility of using two types of blades for cutting vegetation of different thickness, with a diameter of 15 to 30 mm.

The rotor design and the blade selection make TORNADO the ideal choice for the maintenance of urban areas.



SRG

SRG are branch cutters specially designed for removing the tops of trees, as well as large and small vegetation up to 100 mm thick.



BM

BM is a brush designed for removing grass, dirt and leftover winter season spreading agent from roads.



KAN

KAN is a ditch cleaner, designed for cleaning and profiling ditches along roads.

TECHNICAL CHARACTERISTICS

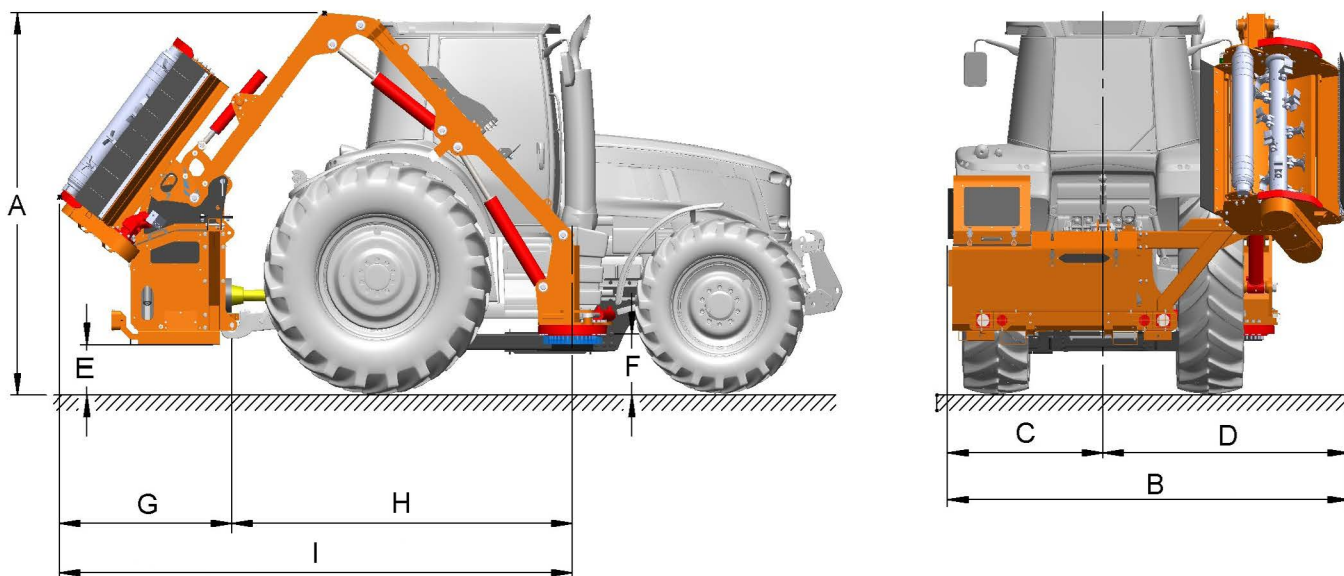

| BRK | | 5000 | 6000 | 7000 |
|----------|---|-----------------------------------|-----------------------------------|-----------------------------------|
| A | Total boom mower height | 2700 | 3200 | 3670 |
| B | Total boom mower width | 2930 | 2930 | 2930 |
| C | Boom mower width from the middle to the extreme left edge | 1130 | 1130 | 1130 |
| D | Boom mower width from the middle to the extreme right edge | 1800 | 1800 | 1800 |
| E | Distance of power unit from the ground | 350 | 350 | 430 |
| F | Distance of mounting point from the ground | ~ 430 (depending on the tractor) | ~ 430 (depending on the tractor) | ~ 500 (depending on the tractor) |
| G | Boom mower length - the distance from the rear three-point hitch to the end point of the power unit | 1250 | 1250 | 1250 |
| H | Boom mower length - the distance from the rear three-point hitch to the mower attachment system | ~ 2470 (depending on the tractor) | ~ 2470 (depending on the tractor) | ~ 2830 (depending on the tractor) |
| I | Total boom mower length in the transport position | ~ 3720 (depending on the tractor) | ~ 3720 (depending on the tractor) | ~ 4080 (depending on the tractor) |



RASCO d.o.o.
 Kolodvorska 120b
 HR - 48361 Kalinovac
 CROATIA

+385 48 883 112
 rasco@rasco.hr

RascoCompany
 Rasco_company

RascoTV
 RASCO d.o.o.