



**More than products. A Partnership.**

# MAXIMA

Side mounted boom mower with a 12 metre reach

MAXIMA is a side mounted boom mower intended for the most demanding mowing, in places where a large reach arm reach is required: very high embankments along waterways, deep canals, along accumulation lakes and on wide areas along high priority roads.





# Efficient mowing of the most demanding terrains

MAXIMA is the largest mower in the RASCO mower range, designed for the most demanding mowing work. It is available in arm configuration with a range of 9, 10 or 12 meters. MAXIMA is mounted on large and heavy tractors, and intended for mowing on difficult terrains, such as very high embankments, deep canals, and very large areas along high priority roads.

MAXIMA is equipped with telescopic arms made of a special type of steel that can withstand increased hand stresses during mowing, which ensure reliable work on terrains where a large reach of arms is required. A double telescopic arm is mounted with an 9- or 10-meter reach, while a triple telescopic arm is mounted with a 12-meter reach mower. MAXIMA can be equipped with professional mowing heads of different sizes, intended for mowing vegetation up to 5 cm thick.

MAXIMA is mounted on the tractor exclusively in RASCO factory. Due to the large reach of the arm, the mower is additionally secured with weights, that stabilize the vehicle when mowing. The installation of the boom mower laterally between the tractor axles and the special construction of the arms guarantees efficient mowing even at higher speeds, reduction of vibrations while working and greater operator comfort. To increase safety and mowing quality, MAXIMA can also be equipped with an auxiliary wheel as an additional support. When the mower is not in operation, the wheel is automatically lifted and rotated into the space between the axles.

The mower is equipped with an advanced intuitive arm control system, located in the vehicle cabin, with fully proportional control (TotalMotion). Optionally, the user can request a camera installation, through which the operator monitors the mowing and the area up to 3 meters in front of the mowing head, directly from the vehicle cabin.

The arm relief system allows vertical tracking of the terrain, while the floating system adjusts the position of the working head to the surface line. The oil cooler located next to the hydraulic power unit prevents overheating of the hydraulic oil and ensures uninterrupted and precise operation during long mowing at high temperatures.

In the transport position, the mower is placed at the rear of the vehicle and marked with light signals aligned with legal regulations, which ensures good visibility and safe participation in traffic.



✓ **Mowing on the most difficult terrains**

It is specially designed for mowing of the most demanding terrains where a large reach of arms is required: the highest embankments and the deepest canals, as well as large open areas along roads of high importance.



✓ **Maximum reach of arms**

MAXIMA is available in 9, 10 or 12 meter arm configurations. A large reach is provided by telescopic arms made of special-purpose steel that can easily withstand the increased strain of the arms when mowing.



✓ **Maximum operational safety**

When installing the MAXIMA mower, the tractor is additionally stabilized with weights. The mower can also be equipped with an auxiliary wheel that serves as an additional support, and when not in use it automatically raises and rotates between the axles.



✓ **Total lowest cost of ownership**

Its unique surface protection system, ease of use and maintenance, robust design, and high-quality materials guarantee a safe investment in the MAXIMA mower.

Proven durability, safety, efficiency, and simplicity, as well as the availability of spare parts and after-sales support, guarantee the lowest total cost of ownership currently available on the market.





### 1 | Operation

The mower is equipped with an advanced and intuitive arm control system and working tools located in the vehicle cabin. The control system is fully proportional (TotalMotion). The control system provides complete control over the machine and enables safe and simple mowing. Additionally a camera can be installed, through which the operator monitors the mowing and the area up to 3 meters in front of the mowing head, directly from the vehicle cabin.

### 2 | Hydraulic power unit

Used for powering of the working tool hydraulic engine and the hydraulic cylinders for operating the arms. It is driven via the cardan output of the tractor on which the mower is installed.

### 3 | Arms

Reliable and durable, they are made out of high quality steel, with a double telescopic arm with 9 or 10 meters reach and triple telescopic arm with 12 meters reach. They provide excellent work results and serve as a universal carrier for various work tools.

### 4 | Additional support for the mower

To further increase safety and mowing quality, MAXIMA can be equipped with an additional auxiliary wheel mounted between the axles, as an additional support. When the mower is not in operation, it automatically lifts and rotates in the space between the axles.

### 5 | Hydraulic oil cooler

Located next to the oil tank, it prevents the hydraulic oil from overheating and ensures long-lasting and uninterrupted operation, regardless of the outside temperatures.

### 6 | Mower mounting frame

A specially adapted mounting frame is used to install the mower between the tractor axles.

The installation of the mower is exclusively done in the RASCO factory. Our expert vehicle upgrade team creates a specially tailored frame for each tractor, which guarantees the stability of the overall composition, safety, and smooth operation.

### 7 | Boom mower relief system

Ensures adapting to the uneven terrains, while the 'floating' system adjusts the position of the working head to the surface. This reduces the load on the hydraulic and mechanical construction of the mower and extends the service life of the device.

### 8 | Swiveling mechanism

It consists of a hydraulic cylinder that allows the mower to quickly turn from transport to the working position. It is also a safety element when the working tool gets stuck on an obstacle.

### 9 | Rear signalization

Enables a good visibility of the mower and the vehicle to which it is mounted and provides a high degree of safety for the user and all other traffic participants.

### 10 | Storage outside the season

Made easier using a supporting cart that enables simple mounting and demounting of the mower. The storage cart protects the mower and the surface on which it is stored from damage.

### 11 | Working tools and attachments

MAXIMA can be equipped with various types of mowing heads, designed for mowing of vegetation up to 5 cm thick.



# Intuitive control systems developed for the user

The control of the boom mower is enabled through an advanced control unit located inside the vehicle cabin. It consists of a joystick for arms and working tools operation, and a color display with working commands for mower relief, floating position, and additional functions.

MAXIMA is available with a TotalMotion control system:



## TOTALMOTION

### Fully proportional control

Fully proportional control is intended for working on difficult terrains, full of obstacles, where continuous manoeuvring with crane arms is required. Control with the use of joystick allows quick changes of the arm position, through the movement of several cylinders in one joystick movement.



## HYDRA

HYDRA is a combined working head for mowing and cutting vegetation up to 50 mm thick. Efficient operation of the HYDRA mowing head is enabled by the design of its key parts. The spiral distribution of the blades reduces energy consumption, and the increased opening at the back of the head allows a high flow of material, and accordingly, a higher mowing speed.

The HYDRA mowing head can be equipped with different types of blades, which enables it to adapt on any type of terrain which is being mowed.



## TORNADO

TORNADO mowing heads are an ideal choice for maintaining smaller vegetation. They are designed to provide the possibility of using two types of blades for cutting vegetation of different thickness, with a diameter of 15 to 30 mm.

The rotor design and the blade selection make TORNADO the ideal choice for the maintenance of urban areas.

# Continuous work in all conditions

The boom mower is driven by a separate hydraulic unit driven by the power of the vehicle on which the mower is installed. Three types of hydraulic pumps can be installed in the hydraulic unit, depending on the mode of operation of the mower and the type of terrain being maintained:

### Hydraulic system with tandem gear pump

Ideal for low to medium intensity work, eg mowing grass and vegetation along roads

**Hydraulic system with tandem piston and gear pump** Ideal for medium to demanding working conditions such as mowing and maintaining vegetation along canal networks

**LS hydraulic system** Advanced hydraulic system ideal for difficult mowing conditions when the mower is running non-stop. The LS hydraulic system is designed for all-day demanding mowing work and enables fuel savings.

### Cooling of the boom mower

The specially designed oil cooler prevents the hydraulic oil from overheating and ensures long-term and uninterrupted operation of the mower, regardless of outside temperatures.





# TECHNICAL CHARACTERISTICS

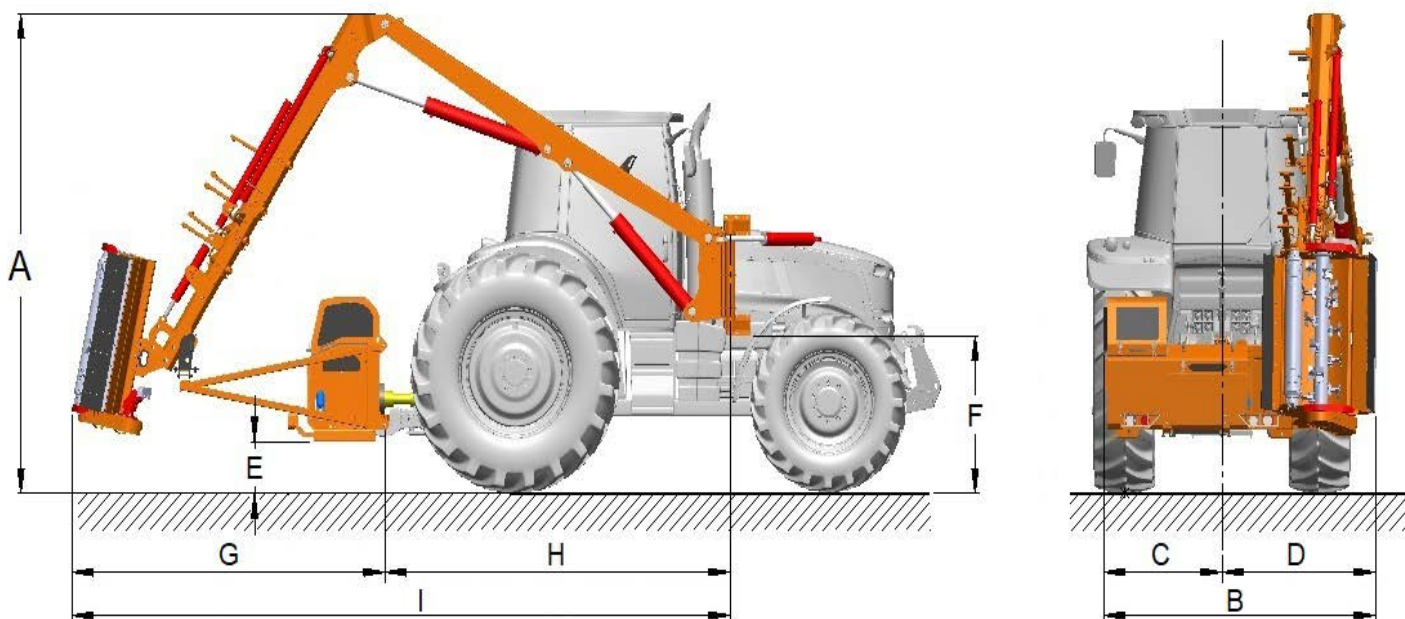

	MAXIMA		9000	10000	12000
A	Total boom mower height	mm	3900	3900	4050
B	Total boom mower width		2730	2730	2730
C	Boom mower width from the middle to the extreme left edge		1130	1130	1130
D	Boom mower width from the middle to the extreme right edge		1600	1600	1600
E	Distance of power unit from the ground		430	430	430
F	Distance of mounting point from the ground		~ 1370 (depending on the tractor)	~ 1370 (depending on the tractor)	~ 1370 (depending on the tractor)
G	Boom mower length - the distance from the rear three-point hitch to the end point of the power unit		2050	2050	3050
H	Boom mower length - the distance from the rear three-point hitch to the mower attachment system		~ 3300 (depending on the tractor)	~ 3300 (depending on the tractor)	~ 3300 (depending on the tractor)
I	Total boom mower length in the transport position		~ 5360 (depending on the tractor)	~ 5360 (depending on the tractor)	~ 6350 (depending on the tractor)



**RASCO d.o.o.**  
 Kolodvorska 120b  
 HR - 48361 Kalinovac  
 CROATIA

+385 48 883 112  
 rasco@rasco.hr

RascoCompany  
 Rasco\_company

RascoTV  
 RASCO d.o.o.