



**More than products. Partnership.**

# TRP

Professional spreader for tractors

Spreader for pre-wetting and dry spreading equipped with a solid agent tank with a volume of 0.4 to 1.5 m<sup>3</sup>, and a liquid agent tank with a volume of 500 litres.

Intended for tractors in winter service. Simple mounting on the rear tractor three-point attachment, and power through the tractor's hydraulic system or a stand-alone hydraulic system.



# Reliable solution for winter service tractors

TRP is a simple, yet professional and reliable solution which turns every tractor into a winter road maintenance vehicle. Equipped with a system for pre-wetting and dry spreading, TRP is a good choice for urban and rural areas where simplicity, efficiency and value for money are the key factors for the selection of road maintenance equipment.

The conveyor system of the TRP spreader consists of counterflow augers that bring the spreading material to the rotating spinner designed for minimising the reflection of the spreading agent from the road surface. The special design of the hopper prevents the adherence of material to the side walls and formation of the tunnel effect and a tarpaulin of high strength covers the top of the hopper in order to protect the spreading material from rain and snow. Spreader's functions are controlled from the cabin of the tractor with the EPOS control unit, which makes TRP equal to truck spreaders with regard to functionality and precision of spreading. Good visibility of the TRP spreader in all winter condition is enabled by reflective and light markings that increase the safety of users and other traffic participants.

Simple mounting on the rear tractor three-point attachment, self-loading mechanism (if TRP is not equipped with a pre-wetting system), robust construction and minimal maintenance requirements make TRP an indispensable addition to every tractor during the winter months.

## Material-mixing shaft

The TRP spreader is available in a version with a built-in shaft for additional mixing of the spreading material.

The shaft prevents the chipping of material inside the tank, especially if using a coarse wet salt and similar heavy spreading agents.

It provides a uniform flow of material to the spinner, minimizing the formation of a tunnel effect inside the spreader.

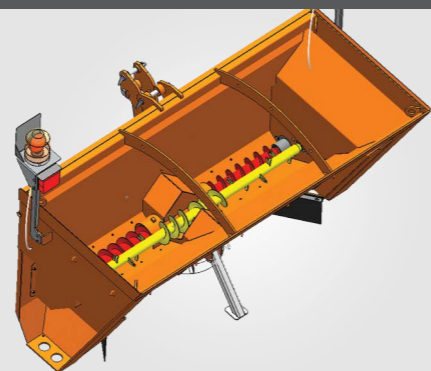

### ✓ Functionality equal to truck spreaders

The asymmetry and width of spreading, as well as the quantity of spreading material are controlled from the cabin of the tractor with an EPOS control unit without the need to look away from the road, which makes TRP equal to truck spreaders with regard to functionality and precision of spreading.

The standard version of TRP comes with a spinner for spreading the material with a spreading width of up to 9 m.



### ✓ Efficient solution for professionals

The TRP spreader turns every tractor into a winter road maintenance vehicle. Its 0.4 to 1.5 m<sup>3</sup> dry agent capacity and 500 L liquid agent capacity make TRP a good choice for urban and rural areas where simplicity, efficiency and value for money are the key factors for the selection of road maintenance equipment.



### ✓ Simple mounting and maintenance

The spreader is mounted on the rear tractor three-point attachment, and powered via the self-loading system.

The special design of the hopper prevents the adherence of material to the side walls and formation of the tunnel effect.



### ✓ Proven quality and reliability

We have incorporated the experience gathered from over 40 markets and three continents where RASCO operates into RASCO spreaders.

The quality, robustness and reliability of RASCO spreaders has been proven on virtually all European roads, from the Arctic Circle across sunny Spain to the toughest winter conditions in Russia and Ukraine.

## BASIC PARTS OF TRP SPREADER

### 1 | Conveyor system

The conveyor system of the TRP spreader consists of counterflow augers that bring the spreading material to the rotating spinner designed for minimising the formation of tunnel effect.

### 2 | Spreading system

Designed in the form of a spinner for spreading materials.

### 3 | Monitoring of use of the spreader

As part of an integrated monitoring system of operation of the spreader and movement of the vehicle, it enables easy and effective management of the winter maintenance fleet. It optimizes the amount of material used for spreading and fuel costs.

### 4 | Traffic signalisation

Installed according to legal regulations in force in the country of use. Reflective labels, rotating lights and illuminated signs ensure good visibility of the spreader and vehicle in all weather conditions.

### 5 | Control units

Ergonomically shaped and simple to use, EPOS control units enable the control of spreading parameters from the vehicle cabin without the need to look away from the road or distracting the driver while driving.

### 6 | Solid agent tank

Available in volumes of 0.4, 0.65, 1.0 and 1.5 m<sup>3</sup>. Its design and manufacturing prevent the adherence of material to the side walls of the spreader, and eliminate the tunnel effect, ensuring a uniform flow of material to the spreading system.



### 7 | Protective mesh on top of the hopper and spreader cover

Protect the spreader from damage during filling of the spreading material and prevent the material from dampening in the solid agent tank.

### 8 | Liquid agent tank

The volume of the liquid agent tank is 500 litres and is available in a version with solid agent tank volume of 1.5 m<sup>3</sup>. It is filled with a previously prepared solution of the agent.

### 9 | System of mounting on vehicles

The spreader is easily mounted on the tractor rear three-point attachment.

### 10 | Self-loading mechanism

TRP is equipped with a mechanism for self-loading of material, which makes the work in winter service even simpler and easier.

### 11 | Powering the spreader

It can be powered in two ways: by the tractor's hydraulic system or by a stand-alone hydraulic system (PTO) installed directly on the spreader.



# Intuitive and advanced control units

The operation of all RASCO spreaders is controlled by EPOS control units. Their dedicated development by RASCO experts makes them a leading solution for spreading control and monitoring. The EPOS family of control units is the result of the knowledge and experience gathered over a quarter of century from over 40 markets where RASCO operates. The result is intuitive control units, easy to use, designed to control the spreader without the need to look away from the road.

TRP spreaders can be controlled using EPOS 1 and EPOS 5 control units. EPOS 1 enables control of spreading width and dosage, and the EPOS 5 adds the options of fully dependant spreading, adjustment of spreading asymmetry image, and control of spreading through feedback connections.

The high reliability of compliance with the set parameters for spreading is achieved by using the system of feedback connections with the working elements of the spreader, while the system of simple and rapid calibration of the spreader ensures precision of spreading using different spreading materials.

## GPS speed sensor



The GPS speed sensor is available for installation on TRP spreaders. Installing a GPS speed sensor is very simple and fast compared to other conventional speed sensors.

The GPS speed sensor provides a greater precision of speed measurement, even at very low speeds, which does not interfere with the spreading process.

# Real-time monitoring of your fleet of winter service vehicles

The current position of the spreader, setting parameters of spreading, working hours, and history of movement and usage data are information that needs to be available at any time. RASCO spreaders are adapted to connect with the systems for monitoring and control.

ARMS is an information and communication system for control, central monitoring, reporting and optimization of activities related to the maintenance of traffic infrastructure. Monitoring of working hours of people and machines as well as of the used resources (such as the used spreading salt, vehicle fuel etc.) in real time creates a unique possibility to quickly decide on potential saving methods. Unchangeable logs protect the user from liability by providing clear information on any taken action, while the reduced consumption of spreading material at the same time protects traffic infrastructure and its surroundings.

The system gathers information on device and vehicle usage in real time using data mobile networks available in almost all countries of the world.

The information collection application is cloud-based and maintained by RASCO experts, which reduces operative costs and the need for system maintenance by users. The user can approach the system through a simple web interface from any computer.

ARMS can be integrated in a larger intelligent transportation system (ITS) or it can be connected to smaller systems such as RWIS (Road Weather Information System).



	EPOS 1	EPOS 5
Control of spreading quantity and width	•	•
Dry spreading	•	•
Wet spreading		•
Travel-dependant spreading		•
Adjustment of spreading asymmetry image		•
Spreading control using feedback connections		•



## TECHNICAL CHARACTERISTICS

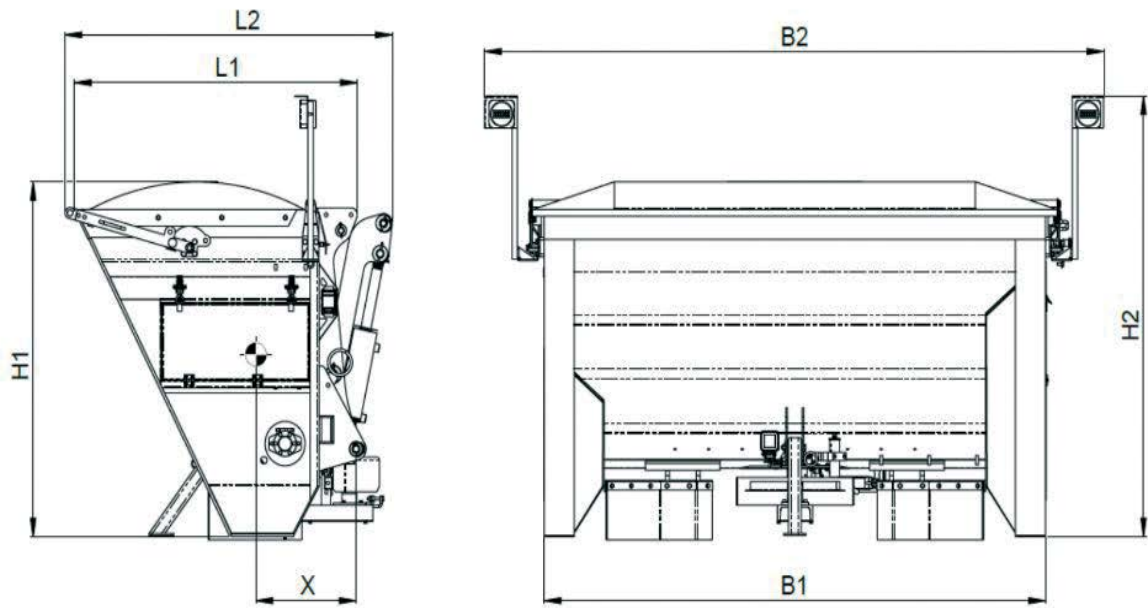

Model	Tank volume		Spreading width m	H1	H2	B1	B2	L1	L2
	Solid agent	Liquid agent		Hopper height	Total spreader height	Hopper width	Total spreader width	Hopper length	Total spreader length
	m <sup>3</sup>	L		mm					
0.4	0.4	-	1 - 6 (2 - 9)	1090	1410	1340	1430	980	1220
0.65	0.65			1230	1510	1630	1740	1100	1220
1.0	1.0			1310	1600	2050	2490	1170	1310
1.5 M	1.5 M	500		1440	1740	2240	2690	1410	1650

## CHOICE OF SPREADER EQUIPMENT

- Spinner 1 ÷ 6 m / 2 ÷ 9 m
- Spreader self-loading mechanism
- Pre-wetting system
- Material-mixing shaft
- Spreader operation automation units, sensors and engines
- ARMS system
- GPS speed sensor
- Work and rotating lights
- Hot-dip galvanized tank
- Stainless steel tank and sieve
- Tarpaulin cover without or with opening mechanism
- Protective mesh and additional cover for auger conveyor



**RASCO d.o.o.**  
Kolodvorska 120b  
HR - 48361 Kalinovac  
CROATIA

+385 48 883 112  
rasco@rasco.hr

RascoCompany  
Rasco\_company

RascoTV  
RASCO d.o.o.