



**More than products. Partnership.**

# LIQUID

Multifunctional liquid agent spreader

Liquid agent spreader for use on roads, available with liquid agent tank capacity of 1500 to 14.000 L.

Designed specifically as a multifunctional device, LIQUID can also be used in the summer as a water tank or as a tank for cleaning and washing the roads.





# Great savings with extended spreading lifetime

Liquid spreading is a proven spreading technology which achieves best results in weather conditions that are characteristic for transitional periods with moderately low temperatures or immediately before the formation of ice on road surfaces. Liquid spreading reduces the total consumption of salt and increases maximum spreading speed, which results in the reduction of operative costs and negative environmental impact, as well as protecting the traffic infrastructure. LIQUID spreaders represent RASCO's answer to all needs for spreading of liquid agents.

Spreading liquids that are used on roads include solutions of sodium, calcium or magnesium chloride or urea. Since liquids adhere to road surfaces better than dry or moist grains of salt, and they can achieve much better road coverage at the same time, liquid spreading prolongs the spreading effect, i.e. it increases residual salinity of the road after the performed spreading.

LIQUID consists of modular polyethylene tanks resistant to extreme weather conditions. The tanks can carry solutions of sodium, calcium or magnesium chloride, urea or other unconventional agents for liquid spreading. The tanks can be filled through the opening at the top or through the standard tubular hydrant connection at the rear end of the spreader. A visual indicator shows the level of liquid in the tanks. A built-in sensor automatically switches off the charging pump when the tanks are filled.

LIQUID's distribution system consists of a ramp with a system of nozzles with variable flow. This patented solution enables high precision of spreading when the vehicle on which the spreader is mounted moves at high speeds. Two different types of nozzles, one of which is used for spreading immediately after the spreader, and the other for left and right lane spreading, provide the possibility not only of a wide spreading pattern, but also of the precise control of spreading asymmetry.

In addition to spreading liquids on roads, LIQUID can be used for de-icing traffic signs during winter and for the maintenance of hard to access areas by the side of roads with the use of a mounted manual jet washer.

Designed specifically as a multifunctional device, LIQUID can also be used in the summer as a water tank in combination with a front cleaner mounted on the vehicle.

With a functional design, high performance quality and low maintenance costs, LIQUID spreaders are a reliable multifunctional solution for winter and summer maintenance of traffic infrastructure.



## WHY CHOOSE THE LIQUID SPREADER? ❖



### ✓ Proven efficiency of spreading technology

Liquid spreading is a proven spreading technology which achieves best results in weather conditions that are characteristic for transitional periods with moderately low temperatures or immediately before the formation of ice on road surfaces.

Since liquids adhere to road surfaces better than dry or moist grains of salt, and they can achieve almost perfect road coverage at the same time, liquid spreading prolongs the spreading effect, i.e. it increases residual salinity of the road after the performed spreading.



### ✓ Savings and environmental protection

Liquid spreading reduces the total consumption of salt and increases maximum spreading speed, which results in the reduction of operative costs and negative environmental impact, as well as protecting the traffic infrastructure.



### ✓ Lowest cost of ownership

Easiness of use and maintenance, robust design, high-quality materials, and hydraulic components produced by renowned manufacturers guarantee a safe investment in the LIQUID spreaders. Proven durability, safety, efficiency, simplicity, and availability of service parts and post-sales support guarantee the lowest overall cost of ownership of a spreader currently available on the market.



### ✓ Multifunctional

LIQUID spreaders can be used in the winter for road anti-icing or de-icing roads where ice has already formed, and in the summer as a water tank.



# From footpaths to airports

LIQUID spreaders can be divided into three families depending on their purpose, liquid agent tank capacities, and the available spreading widths: LIQUID S, LIQUID M and LIQUID.



**LIQUID S**

LIQUID S is a liquid agent spreader for preventive treatment or de-icing of pedestrian and cycling paths and all other traffic areas where winter maintenance is performed by means of small transporters, multifunctional vehicles, pick-up vehicles or light-duty vehicles.

It is available with liquid agent tank capacity of 1500, 2000 or 2500 L. The spreader can be operated at a fixed width of 2 or 3 meters, and a variable width of 2 to 6 meters at intervals of 1 m, depending on the type of ramp with nozzles.



**LIQUID M**

LIQUID M is intended for treatment of local roads, pedestrian and cycling paths and similar traffic areas where winter maintenance is performed using Unimog multi-purpose vehicles, smaller trucks or a spreader mounted on a trailer.

It is available with liquid agent tank capacity of 3000, 4000 or 5000 L. The spreader can be operated at a fixed width of 2 or 3 meters, and a variable width of 2 to 6 meters at intervals of 1 m, depending on the type of ramp with nozzles.



**LIQUID**

LIQUID spreaders are available with liquid agent tank capacity of 6000 to 14.000 L. They are designed to be mounted onto trucks, towing trailers and Unimog multi-purpose vehicles.

In contrast to the LIQUID S and M, LIQUID can spray liquids in a larger width: up to 12 meters. Liquid spraying nozzles can be turned off individually, which expands or narrows the spreading width at intervals of 1 meter, or in groups, with one group covering the width of a single traffic lane.



## Preparation of liquid spreading agent

In order to always have a sufficient amount of liquid prepared in the desired ratio at your disposal, you will need a device for quick and easy preparation of the solution. MMS is RASCO's solution for the preparation, mixing and storage of liquid spreading agent.

It allows quick dissolution of materials in water by using a high-flow pump that creates a strong vortex inside the container. It is available with capacities of 4 to 8 m<sup>3</sup>, and for storage of liquids additional containers with capacities from 5000 to 50.000 L are available.

# Solution for vehicles with and without built-in hydraulic system



### Vehicles with built-in hydraulic system

LIQUID spreaders can be powered using a built-in hydraulic system of the vehicle if it is designed according to the EN ISO 15431 standard.

If the hydraulic system of the vehicle is equipped with Load Sensing, the spreader must be equipped with a compatible hydraulic installation that is available as an option.



### Vehicles without built-in hydraulic system

If the vehicle is not equipped with a hydraulic system, the LIQUID spreader can be powered using the highly reliable diesel-hydraulic power unit which is available as an option with the spreader. With this solution, the spreader becomes independent of the vehicle and can be easily and quickly moved to any carrier vehicle of sufficient capacity. In a particular edition, the diesel-hydraulic power unit mounted on the spreader can be used to power the front or side plough.

## MOUNTING OF LIQUID SPREADERS

# Every spreader needs a vehicle

LIQUID spreaders can be mounted on almost any vehicle intended for winter maintenance. With easy mounting onto vehicles, there are also a variety of mounting options for the LIQUID spreader:

- Mounting on dump box
- Mounting on dump box balls
- Mounting directly on vehicle chassis
- Mounting on trailers
- Mounting on vehicles equipped with hooklift system



### RASCO spreader safety

- ✓ Mounting the spreader on vehicles is performed according to strict safety standards and recommendations of the vehicle manufacturer.
- ✓ The spreaders can be quickly and easily mounted or de-mounted from vehicles.
- ✓ Multiple safety elements protect the user during spreader operation and maintenance.
- ✓ Spreaders are marked with light and reflective markings that ensure visibility of the winter service vehicle regardless of weather conditions.



# Intuitive and advanced control units

The work of all RASCO spreaders is controlled by EPOS control units. Their dedicated development by RASCO experts in cooperation with the users makes them a leading solution for spreading control and monitoring. The EPOS family of control units is the result of the knowledge and experience gathered in the quarter of century in over 40 markets where RASCO operates. The result is intuitive control units, easy to use, designed for controlling the spreader without taking your eyes off the road.

LIQUID spreaders can be controlled with EPOS 10 and EPOS 30 control units. EPOS 10 enables control of all spreader functions, and EPOS 30 adds the option of wireless connectivity, GPS automatic spreading, navigation, and front and side snow plough control.

The high reliability of compliance with the set parameters is achieved by using the system of feedback connections with the spreader's actuators, and the simple and rapid calibration system of the spreader ensures precision of spreading using different spreading materials.



## Geolocation and navigation in the service of winter road maintenance

Geolocation of vehicles and navigation are standard functionalities that are used primarily for easier and faster navigation on the roads.

They can be used in the winter road maintenance service for faster, easier and more reliable maintenance of smooth traffic flow. Record the routes used by winter road maintenance vehicles once. Add spreading parameters to segments of recorded routes. After that, the winter road maintenance drivers must only follow the instructions of the navigation system, and adjusting of the spreading parameters is fully left to the EPOS 30 control unit according to the pre-set parameters.

EPOS	10	30
Control of spreading quantity and width	•	•
Dry spreading	•	•
Wet spreading	•	•
Liquid spreading	•	•
Travel-dependant spreading	•	•
Adjustment of the spreading pattern asymmetry	•	•
Spreading control using feedback connections	•	•
Separate adjustment of left and right spreading width	•	•
Thermal camera	•	•
Automatic spreading using GPS location and predefined routes		•
Online & offline maps		•
Connectivity via Bluetooth and Wi-Fi		•
Compatibility with additional control units (e.g. for front/side snow plough)		•



# Keep track of your winter service fleet of vehicles in real time

The current position of the spreader, spreading parameters settings, working hours, and historical movement and usage data are information that you need available at any time. RASCO spreaders are adapted for connecting with monitoring and tracking systems.

ARMS is RASCO's software solution for monitoring and tracking – an information and communication system for control, central monitoring, reporting and optimization of activities related to the maintenance of traffic infrastructure. Monitoring of working hours of people and machines as well as of the used resources (such as the used spreading salt, vehicle fuel etc.) in real time provides a unique possibility to quickly decide on potential saving methods. Unchangeable logs protect the user from responsibility by providing clear information on any taken action, while the reduced consumption of spreading material at the same time protects traffic infrastructure and its surroundings.

The system gathers information on device and vehicle usage in real time using a data mobile approach, standard in almost all countries of the world.

The application which collects information is placed in the “cloud” and is maintained by RASCO experts, which reduces operative costs and the need for system maintenance by users. The user can approach the system through a simple web interface from any computer.

ARMS can be integrated in a larger intelligent transportation system (ITS) or it can be connected to smaller systems such as RWIS (Road Weather Information System).





## TECHNICAL CHARACTERISTICS

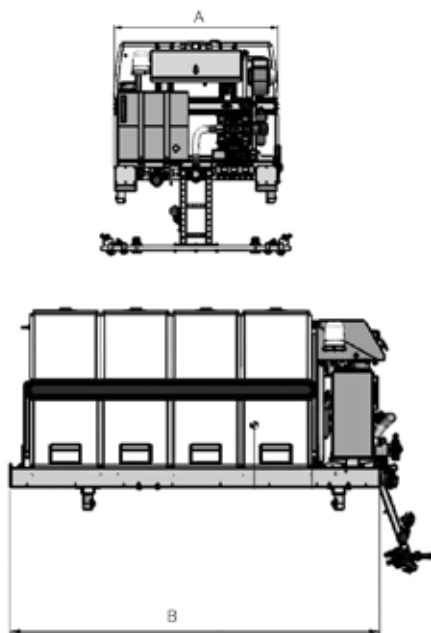

**LIQUID S / M**

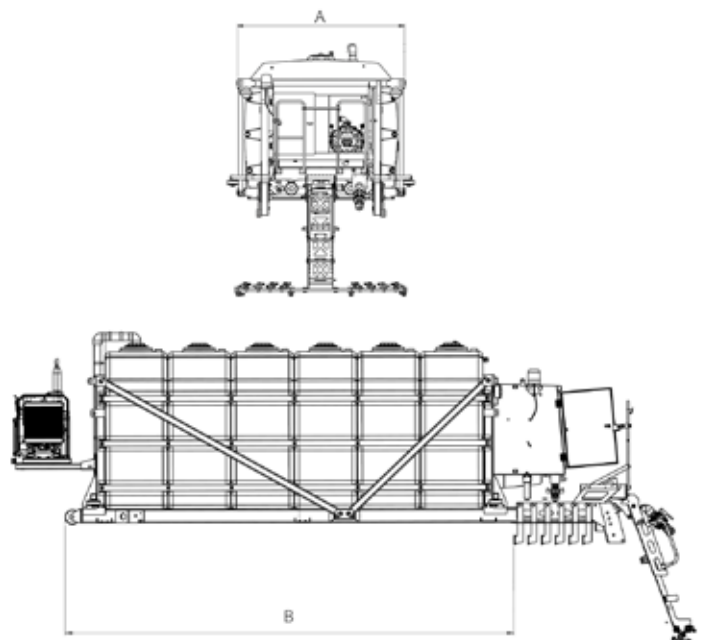

**LIQUID**

Model	Capacity L	A	B	Spreading width m
		Maximum device width mm	Necessary length of mounting box mm	
S 1.5	1500	1304	1910	2 / 3 fixed or 2-6 adjustable
S 2.0	2000		2360	
S 2.5	2500		2810	
M 3.0	3000	2010	2257	
M 4.0	4000		2822	
M 5.0	5000		3387	
6.0	6000	2250	3110	2 ÷ 12 (10-200 ml)
8.0	8000		3460	
10.0	10000		4140	
12.0	12000		4910	
14.0	14000		5600	

## CHOICE OF SPREADER EQUIPMENT

- Manual pressure washer with hose reel
- Variety of mounting options
- Storage legs
- Control units, sensors, cameras
- ARMS system
- Multiple spreader drive options
- Work lights and rotating lights
- Reflective marks



**RASCO d.o.o.**  
Kolodvorska 120b  
HR - 48361 Kalinovac  
CROATIA

+385 48 883 112  
rasco@rasco.hr

RascoCompany  
Rasco\_company

RascoTV  
RASCO d.o.o.